

TURN SIGNAL ELIMINATION FOR 2000 KAWASAKI VULCAN DRIFTER  
(USING THE FACTORY SPOTLIGHTS WITH P 36 SEALED BULBS)

THIS MODIFICATION IS NOT DOT APPROVED

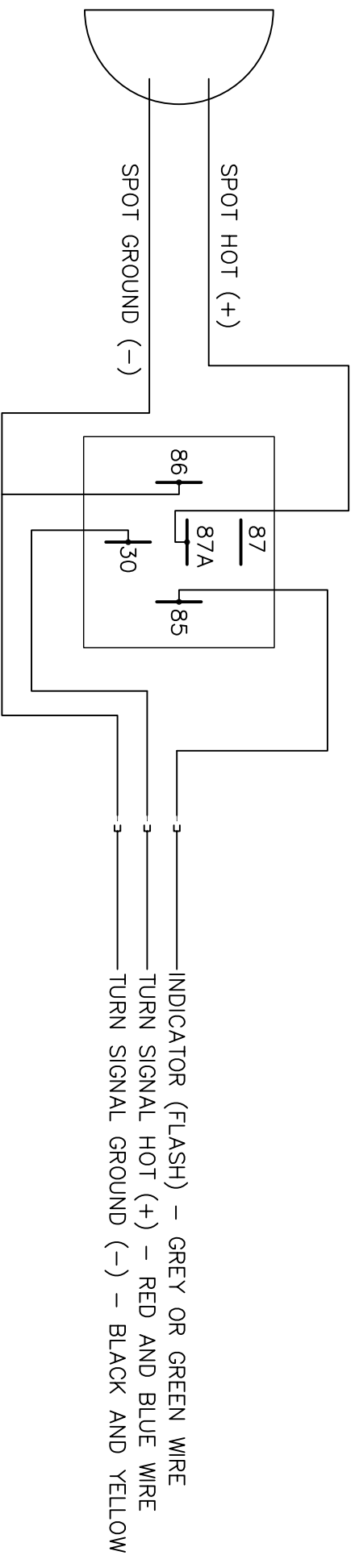

FOR WHAT IT IS WORTH~

- RELAY IS A 12V 30W STANDARD SPDT AUTO RELAY AVAILABLE ONLINE OR AT MOST ELECTRONICS STORES CHECK A GOOD STEREO OR ALARM SHOP
- (RADIO SHACK DID NOT STOCK IT)
- I USED PIN CONNECTORS TO PUSH RIGHT INTO THE FACTORY CONNECTIONS
- 16 GAUGE WIRE IS VERY HARD TO GET THROUGH THE OPENINGS IN THE FACTORY SPOT
- I SUGGEST 18 GAUGE WIRE BASED ON ABOVE
- I SOLDERED ALL THE JOINTS WITH FITTINGS
- SINGLE RELAY, WIRES AND SINGLE CONNECTOR WILL FIT THROUGH THE HOLE IN THE BACK OF THE HEADLIGHT
- I CONNECTED ALL THE GROUNDS IN THE FEMALE AT THE #86 PIN CONNECTOR.